

Evaluation of Z-Source Inverter Topologies for Power Conditioning Unit for DC Power Supply Systems

Pravin Ratanlal Choube, Vikas Kumar Aharwal*

Electrical and Electronics Engineering (EX) Department, Dr. APJ Abdul Kalam University, Indore, Madhya Pradesh, India.

Received on: 01-June-2022, Accepted and Published on: 01-Sept-2022

ABSTRACT

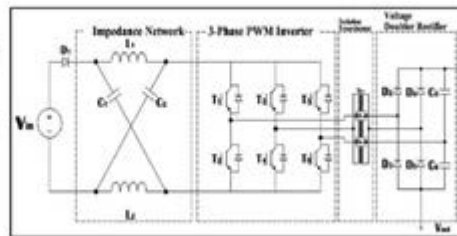
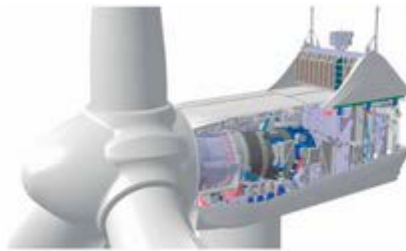

In order to operate a wind turbine generator, careful and extensive research is required as different environmental conditions result in different wind speeds. Standard type of induction generators and compatible electric generators are great in the construction of low-speed applications. Due to the improved architecture and lower PM material emissions, a permanent magnet generator is an ideal choice for low-speed direct applications. Different topologies of permanent magnet generator are available, such as radial flux, axial flux, and transverse flux PMG. The sophisticated structure of the permanent axial flux generator is not suitable for use in large wind turbines. Due to the simple structure of radial flux PMG, the formation of multiple poles can be easily incorporated into the nacelle of wind turbines. To overcome these obstacles, this research project proposes a new topology quasi-Z-source Matrix converter-based DC / DC using a zigzag transformer, and simulation is performed and compared with other existing DC-based Z-source converters. DC will be approved at the beginning of the power supply unit in DC power supply systems.

Keywords: Z-Source Inverter, Power Conditioning, Dc Power Supply Systems, DC-DC Converter, Wind Systems

INTRODUCTION

Normal energy sources are depleted rapidly due to rising consumption rates. This creates the need for more energy sources. Of all the unusual resources, wind power is the most attractive because of its versatility. There is a lot of ongoing research work on combining energy from wind.¹ The fixed wind speed conversion system has negative energy intake, mechanical compression, etc. The newly installed wind turbine generators use Direct Driven Wind Energy Conversion Systems (DDECS) with permanent magnet generators, and these systems use a three-phase power conversion system which leads to high conversion losses.² The

main goal of this study is to reduce this conversion loss by reducing the number of steps in the energy conversion process.

Renewable energy sources are gaining more attention these days as conventional sources such as oil, gas, and coal have been depleted in the last 30 years. Wind and solar power systems are considered to be the most important types of renewable energy sources³⁻⁶ In particular, the wind energy conversion program is a major source of renewable energy sources in developing countries. India has 1,02,788 MW of wind power (Indian Wind Energy Association Report). However, the installed capacity is only 23,499 MW. Therefore, there is a huge gap between the installed volume and the current power. In addition, current wind turbine generators cannot pull power at low wind speeds. Conventional generators can provide power from 600 rpm to 2000 rpm, but conventional wind turbines are designed to operate at a distance of 20 rpm to 200 rpm. Therefore, only the gearbox can connect between the turbine and the generator. The electric generator must be connected directly to the wind turbine to increase efficiency and avoid gearboxes. Common types of generators, such as non-synchronized generators or compatible generators, require a large number of poles to operate

*Corresponding Author: Pravin Ratanlal Choube
Email: pravinchoube2007@gmail.com

Cite as: J. Integr. Sci. Technol., 2022, 10(3), 209-214.

©ScienceIN ISSN: 2321-4635 <http://pubs.iscience.in/jist>

at low speeds. Therefore, the size of the machine will be larger.⁷ The efficiency and power factor of these generators are also very low. They also require high initial torque and complex braking methods.

Nowadays, improving the properties of permanent magnet materials and reducing the price is a very attractive permanent magnet generator DDWECS.⁸ Permanent magnet generator does not require a DC source to stimulate the field, the construction of a base armature is also possible; therefore, PMG efficiency is always higher than conventional generators. Due to low size and high flux density (Max = 1.4 tesla); PMG can be built with multiple poles in a compact area. PMG requires low initial torque and operating torque due to its reduced weight, so it can generate power at low wind speeds. PMG velocity can be easily calculated by multiplying the frequency of PMG produced by the number of poles. Thus, the sensors under Maximum Power Point Tracking (MPPT) can be easily designed. However, standard types of generators require a position sensor and sophisticated vector control algorithms in order to operate at very high points. Direct drive turbine generator voltage and frequency are constantly changing at wind speed.⁹ Therefore, optical power circuit circuits are required to control the voltage. There are many topologies based on electrical power that are already used in DDWECS.⁸

REVIEW OF LITERATURE

Indirect Z-Source matrix converter PWM approaches for power quality improvement have been discussed by Xiong et.al.¹⁰ As a result, constructing the resulting topology is a breeze. Non-trivial if advantages such as flexibility, minimal commutation count and ease of implementation are taken into consideration. In the switching systems for higher shoot through, commutation overlap, on the other hand, may lead to bigger spikes across the power switches.¹⁰

Z-source matrix converters are now available for purchase. Using a basic voltage-fed Z source matrix converter as an example, their concepts and features are analyzed. The buck boost function can be added to the Z source matrix converter with only three additional switches, resulting in lower costs and more dependability.¹¹

A new twin bridge matrix converter topology with Z-source concept has been proposed to achieve a greater voltage transfer rate.¹² To get around the constraints of the typical matrix converter, a new control method was devised. Using the Z-source network's voltage boost capabilities, the voltage transfer ratio of the system can be increased. While maintaining a high system voltage transfer ratio, the topology's performance is tested against atypical input voltage disturbances. A few energy storage components are required for the suggested topology.¹²

Ekrem Karaman et al. (2014)¹³ have demonstrated a matrix converter topology using the fewest possible semiconductor switches. In either the positive or negative rail, the series Z-source network is connected between the rectifier stage with three switches and the inverter stage with six switches. The converter's boosting capacity may be increased while switching losses are kept to a minimum thanks to the development of an effective PWM approach

and a quick shoot through state. Nevertheless, the switches' inrush current and Z-source capacitor's voltage stress grow.¹³

Omar Ellubbann et al. (2015)¹⁴ have discussed an overview of Z-source matrix converters. There includes a full discussion of the various matrix Z-source converter topologies and setups, circuit analysis and modulation schemes. To overcome voltage gain constraints of the classic matrix converter and achieve buck and boost conditions with a decreased number of switches, the Z-source matrix converter topology employs the Z-source method.¹⁴

PMSG-based variable-speed Wind Energy Conversion Systems (WECS) have become a hot topic among academics in the recent years. The goal of study by Anjana Jain et.al (2018)¹⁵ is to compare the maximum power outputs of several synchronous machines. It discusses different elements of PMSG, including topologies with controlled and uncontrolled rectifiers, grid-connected and standalone mode of operation, and various control techniques of PMSG-based WECS and contemporary optimization approaches. A range of control mechanisms and advanced optimization approaches may be used to improve the PMSG's performance analysis. An evaluation of the pros and cons of the various methods is done in order to make a more informed decision.¹⁵

B. Kumar et al. (2018)¹⁶ has proposed the indirect z-source matrix converter for micro grid applications. The controller designed with harmonic compensator to control the line voltage during nonlinear loads. The performance of the proposed converter is tested with unbalanced and nonlinear loads. However, the transient voltage is higher at shoot periods, hence this topology requires separate controller for controlling the spikes across power switches.¹⁶

The control Z-source matrix converter has been presented by Ismeil et al. (2019).¹⁷ The ZSMC is controlled using a model predictive control approach. MPC models are used to forecast future values of topology parameters including capacitor voltage, inductor current, and load current. Using this strategy, we were able to keep track of the controlled variables' reference values. Shoot-through placement isn't dispersed evenly, which increases switching stress and losses.¹⁷

Wind turbine variable speed converters may be easily controlled using existing electronics, as demonstrated by varying design control. The squawking causes a significant increase in mechanical stress, which may, however, be mitigated by employing various approaches. A number of control methods may be used to enhance the overall assessment of PMSG's overall performance. An in-depth examination of the methodologies' qualitative merits and drawbacks is carried out by Y. Mastanamma (2019).¹⁸

Electric vehicles, the conversion of renewable energy sources, and a wide range of industrial applications all rely heavily on power electronics. They have the capacity to aid in the development of power systems that are more efficient and effective. Voltage and current source inverters, for example, are two examples of classic inverters that have certain drawbacks. As a result, a lot of work has been put into designing novel power electronics converters that may be employed in a wide variety of applications. Single stage Z-source inverter (ZSI) has a cheaper design cost and higher efficiency than the standard

two-stage inverter. In the power electronics circuit,¹⁹ DC input voltage is converted to a specified magnitude and frequency of symmetrical AC output voltage. In distributed generating systems, ZSIs have recently replaced traditional two-stage inverters. ZSI has undergone a number of changes in order to increase its performance and efficiency. For electric cars with multiple power sources, this study looks at the current state-of-the-art impedance source inverter topologies. A brief overview of the most common topologies is given. All of the topologies' structural distinctions and advantages and drawbacks are laid bare. The integrated quasi-Z-source inverter is one of the potential designs that may be employed in multi-source electric cars, with greater performance and reliability, according to this current evaluation of impedance source inverters. There will be a significant influence on electric cars due to the use of this novel topology (EVs).¹⁹

With the increasing use of large-scale renewable energy sources and electric cars, grid integration requires significant advances in power electronic converter technology as well as new control methodologies. Power quality issues on the grid are compensated for, DC systems are protected and grounded, interactions in mixed AC/DC systems are addressed, AC/DC and magnetic system stability is improved, magnetic design for high-frequency high power density systems using advanced soft magnetic materials, modeling and simulation of mixed AC/DC systems, switching strategies for improved efficiency, and p Professionals working in the fields of renewable energy and power conversion can benefit greatly.²⁰

PROPOSED Z SOURCE INVERTER BASED DC/DC CONVERTERS

A. Two Level Z Source Inverter Based DC/DC Converter

When a two-level Z-inverter (ZSI) and a voltage doubler rectifier (VDR) are combined, they form the DC / DC converter shown in Figure 1. Ac voltage is transmitted to the VDR by an isolation transformer. Ac voltage transformer is used to generate dc voltage through a VDR circuit.²¹

B. Single Phase Quasi-Z Source Network Based DC/DC Converter

Graphical imaging is used to amplify the voltage of a fed fed quasi-Z source inverter (QZSI) by continuous input current mounted on the input side of the converter as shown in Figure 2. It is possible to increase the magnetic field in dc inductors L1 and L2 of qZSI without damaging the dc capacitors by using a shot in position. In traditional (operating) inverter systems, the voltage increase seen in the transformer primary winding is caused by an increase in inductive power.

Shoot-through duty cycles are initially adjusted to stabilize the outgoing PV voltage; later, a constant voltage is transmitted to the separation transformer.

C. Three Phase Quasi-Z Source Network Based DC/DC Converters

A three-phase network converter based on quasi-Z source based on DC / DC and VDR configuration is used to increase the power density of the power converters, as shown in Figure 3, with an extra leg switch, a line divider converter, and more rectifier diode leg.

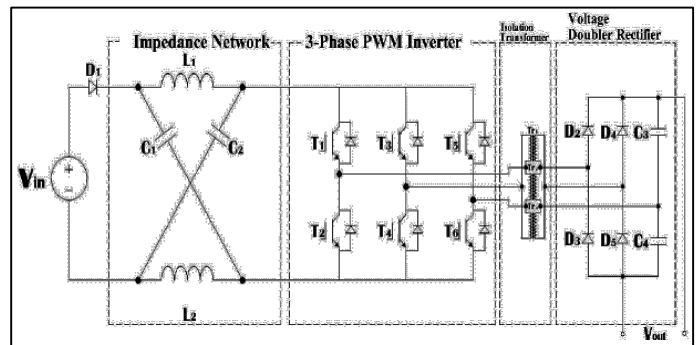

Figure 1: Two level Z Source Inverter-Based DC/DC Converter

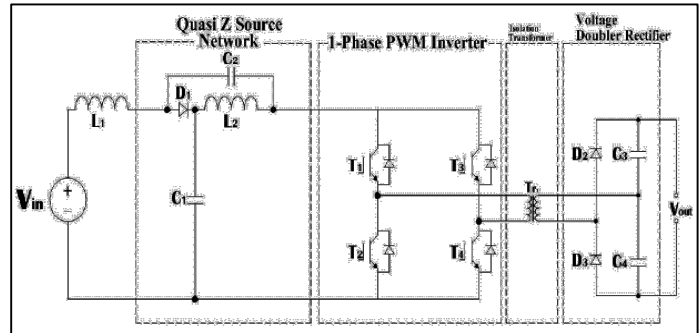

Figure 2: Single Phase Quasi-Z Source Network-Based DC/DC Converter

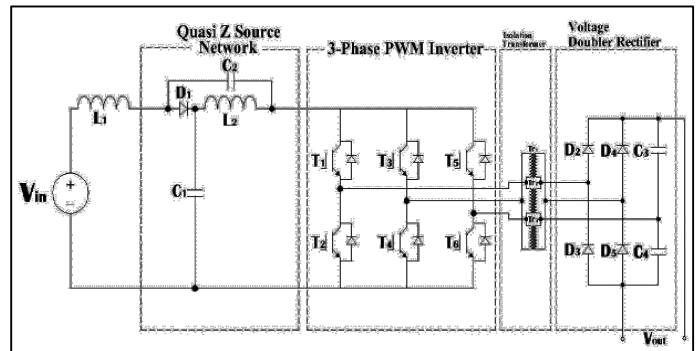

Figure 3: Three Phase Quasi-Z Source Network-Based DC/DC Converter with Isolation Transformer and VDR

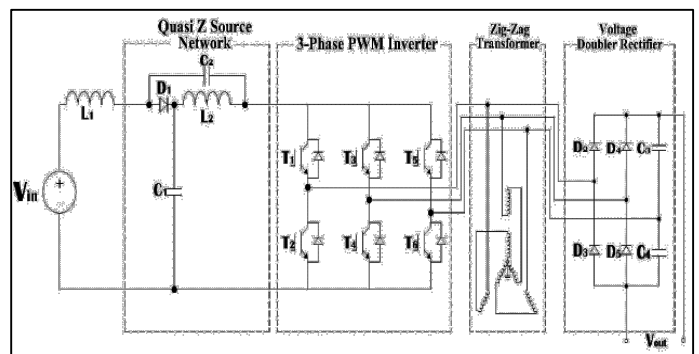

Figure 4: Proposed Three Phase Quasi-Z Source Network-Based DC/DC Converter with Zigzag Transformer and VDR

For additional functions and splits, these DC / DC converters use a straight or zigzag transformer. Figure 3 shows a zigzag transformer that can be used instead of a linear transformer in the cycle described in Figure 4.

SIMULATION RESULTS

At a given input voltage of 70V, the following parameters $L_1 = L_2 = 2mH$, $C_1 = C_2 = 20\mu F$ and capacitors C_3 and C_4 various values such as 1.5 μF , 15 μF and 150 μF are randomly selected for the converter. DC / DC discussed above. Topology and simulation are performed under three different switching systems with a frequency switch of 20 KHz, and a modulation indicator of the value of 1.

The dc output voltage obtained from these DC / DC converters and the power allocated to capacitors C_3 and C_4 for a double voltage reset circuit are presented in Tables 1 to 8.

Table 1: Output Dc Voltage Obtained for Two Level Z Source Inverter-Based DC/DC Converter for Various Values of Capacitors C_3 and C_4 at Different Switching Schemes

Capacitor Values (C_3 and C_4 in μF)	Output DC Voltage (in volts)		
	Simple Boost PWM	Carrier based PWM	SVPWM
1.5	102.6	110.3	109.4
15	116.2	106.8	108.5
150	85.2	82.56	86.76

Table 2: Voltage Stress Shared by Capacitors C_3 and C_4 of Two-Level Z Source Inverter-Based DC/DC Converter

Capacitor Values (C_3 and C_4 in μF)	Voltage Shared by Capacitors C_3 and C_4 (in volts)		
	Simple Boost PWM	Carrier based PWM	SVPWM
1.5	(57.05 V, 45.57V)	(45.87 V, 64.46V)	(59.20 V, 50.20 V)
15	(65.25 V, 50.95 V)	(44.88 V, 61.92 V)	(62.23 V, 46.22 V)
150	(43.10 V, 42.10 V)	(41.62 V, 40.94 V)	(43.49 V, 43.27 V)

Table 3: Output Dc Voltage Obtained for Single Phase Quasi-Z Source Network-Based DC/DC Converter for Various Values of Capacitors C_3 and C_4 at Different Switching Schemes

Capacitor Values (C_3 and C_4 in μF)	Output DC Voltage (in volts)		
	Simple Boost PWM	Carrier based PWM	SVPWM
1.5	105.5	122.7	123.4
15	116.1	120.4	120.8
150	66.65	88.52	74.67

Table 4: Voltage Stress Shared by Capacitors C_3 and C_4 of Single-Phase Quasi-Z Source Network-Based DC/DC Converter

Capacitor Values (C_3 and C_4 in μF)	Voltage Shared by Capacitors C_3 and C_4 (in volts)		
	Simple Boost PWM	Carrier based PWM	SVPWM
1.5	(52.74 V, 52.81 V)	(67.9 V, 54.76V)	(58.99 V, 64.45V)
15	(54.33 V, 61.81 V)	(58.51 V, 61.87 V)	(57.74 V, 63.02V)
150	(32.09 V, 34.56 V)	(41.55 V, 45.96 V)	(36.71V, 37.96 V)

Table 5: Output Dc Voltage Obtained for Three Phase Quasi Z Source Network Based DC/DC Converter with Isolation Transformer and VDR for Various Values of Capacitors C_3 and C_4 at Different Switching Schemes

Capacitor Values (C_3 and C_4 in μF)	Output DC Voltage (in volts)		
	Simple Boost PWM	Carrier based PWM	SVPWM
1.5	97.91	104.6	103.8
15	111.8	102.8	103.6
150	84.01	73.31	85.35

Table 6: Voltage Stress Shared by Capacitors C_3 and C_4 of Three Phase Quasi Z Source Network Based DC/DC Converter with Isolation Transformer and VDR

Capacitor Values (C_3 and C_4 in μF)	Voltage Shared by Capacitors C_3 and C_4 (in volts)		
	Simple Boost PWM	Carrier based PWM	SVPWM
1.5	(53.1 V, 44.81 V)	(42.85 V, 61.74 V)	(56.13 V, 47.53V)
15	(62.23 V, 49.56 V)	(43.45 V, 59.37 V)	(59.05 V, 44.54 V)
150	(42.59 V, 41.42 V)	(38.84 V, 34.47 V)	(42.43V, 42.92V)

Table 7: Output Dc Voltage Obtained for Proposed Three Phases Quasi-Z Source Network-Based DC/DC Converter with Zigzag Transformer and VDR for Various Values of Capacitors C_3 and C_4 at Different Switching Schemes

Capacitor Values (C_3 and C_4 in μF)	Output DC Voltage (in volts)		
	Simple Boost PWM	Carrier based PWM	SVPWM
1.5	951.9	830.3	1063
15	783.4	759.9	866.1
150	391.8	392.9	440.2

Table 8: Voltage Stress Shared by Capacitors C₃ and C₄ of Proposed Three Phases Quasi-Z Source Network-Based DC/DC Converter with Zigzag Transformer and VDR

Capacitor Values (C ₃ and C ₄ in μ F)	Voltage shared by capacitors C ₃ and C ₄ (in volts)		
	Simple Boost PWM	Carrier based PWM	SVPWM
1.5	(521.1 V, 430.8 V)	(424.7 V, 405.8 V)	(588.3 V, 474.4 V)
15	(401.1V, 382.3 V)	(374 V, 385.9 V)	(445.7, 420.4 V)
150	(196 V, 195.8 V)	(197.7 V, 195.2 V)	(219.8 V, 220.4 V)

In the tables above, it is noted that the selection of voltage doubler rectifier circuit capacitor affects the output voltage dc of DC / DC converters and it can be noted that the power sharing between capacitors C₃ and C₄ is almost equal, if the capacitor value selected as 150 μ F. Compared to previous DC / DC-based Z-based converters, the proposed three-phase DC / DC source network with a zigzag transformer and VDR offers significant output power output.

DISCUSSION

Table 1 presents the results for the two-level Z source converter. The capacitor values are increased and the output voltage is observed with different values. It was observed that, the simple, carrier based and SV PWM technique-based outputs are presented. The output voltage for different converters shows that, for simple PWM 15 μ F value gives the maximum output whereas the other two converters give the maximum output at 1.5 μ F value of the capacitors.

Table 2 presents the voltage stress on capacitors C₃ and C₄. It is observed that, when capacitor value is 150 μ F, both capacitors have nearly equal voltage stress, while for lower values of the capacitors, the voltage stress is uneven on both capacitors and it varies with capacitor values.

Table 3-4 shows the performance of the single-phase converter with different switching techniques. 15 μ F capacitor value given better output for simple PWM converter, while other two techniques give the better output with low values of the capacitors. The voltage stress on the capacitors remains nearly 50% with high values of capacitors while it is not equally distributed with lower values.

Table 5-6 presents the performance of the three-phase quasi-Z-source network with different combinations. The performance is nearly similar to the single-phase combinations discussed earlier. The voltage sharing of the capacitors shows the same nature as that of single-phase converter.

Table 7-8 presents the performance of three phase quasi-Z source combination with different switching. The proposed converter output is presented in the table. Better voltage/power sharing is observed with the high value of capacitors while the output voltage is the function of the capacitor values and it varies with different

combinations of the switching networks for capacitor values from low to high.

CONCLUSION

The Topological research of the ZSI source inverter topology given in this chapter is done using complete simulations that offer various benefits over other ZSI topics, such as advanced development capabilities and high waveform quality. A different Z source based on inverter-based converter topology for DC / DC is also being tested. A three-phase quasi-Z-based network converter based on DC / DC flexible zigzag has a stronger converter than other classic Z-based ZO-based topology, according to the simulation test. The Z source view can be applied to any power setting unit, and it has been shown that many Z-source conversion modes can be developed from complete simulation studies done to date.

ACKNOWLEDGMENTS

Authors acknowledge support from Dr. APJ Abdul Kalam University, Indore for infrastructure.

CONFLICT OF INTEREST

Authors declare no conflict of interest is there for publication of this work.

REFERENCES AND NOTES

1. X. Peng, Z. Liu, D. Jiang. A review of multiphase energy conversion in wind power generation. *Renew. Sustain. Energy Rev.* **2021**, 147, 111172.
2. J. Yan, H. Lin, Y. Feng, Z.Q. Zhu. Control of a grid-connected direct-drive wind energy conversion system. *Renew. Energy* **2014**, 66, 371–380.
3. F. Ueckerdt, R. Brecha, G. Luderer. Analyzing major challenges of wind and solar variability in power systems. *Renew. Energy* **2015**, 81, 1–10.
4. F. Weschenfelder, G. de Novaes Pires Leite, A.C. Araújo da Costa, et al. A review on the complementarity between grid-connected solar and wind power systems. *J. Clean. Prod.* **2020**, 257, 120617.
5. A. Patsha, S. Dhara, S. Chattopadhyay, K.-H. Chen, L.-C. Chen. Optoelectronic properties of single and array of 1-D III-nitride nanostructures: An approach to light-driven device and energy resourcing. *J. Mater. Nanosci.* **2018**, 5 (1), 1–22.
6. T.V.B. Nagaveni, K.M. Mahadevan, R. Naik, T.O.S. Kumara. Synthesis of blue light emitting 5-carboxylicacid-2-arylsubstituted benzimidazoles as photosensitizers for dye-sensitized solar cells. *J. Mater. Nanosci.* **2020**, 7 (1), 24–28.
7. Z. Yue, W. Fengxiang. Choice of Pole-Slot number combination for PM generator Direct-Driven by wind turbine. *2008 Jt. Int. Conf. Power Syst. Technol. POWERCON IEEE Power India Conf. POWERCON 2008* **2008**.
8. Y. Li, L. Huang, M. Chen, P. Tan, M. Hu. A Linear-Rotating Axial Flux Permanent Magnet Generator for Direct Drive Wave Energy Conversion. In *2021 13th International Symposium on Linear Drives for Industry Applications (LDIA)*; IEEE, **2021**; pp 1–4.
9. P.R. Choube, V.K. Aharwal. Development of suitable closed loop system for effective wind power control using different ZSC topologies and different switching techniques. *J. Integr. Sci. Technol.* **2022**, 10 (2), 156–167.
10. X. Liu, P.C. Loh, F.Z. Peng, P. Wang, F. Gao. Modulation of three-level Z-source indirect matrix converter. *2010 IEEE Energy Convers. Congr. Expo. ECCE 2010 - Proc.* **2010**, 3195–3201.
11. B. Ge, Q. Lei, W. Qian, F.Z. Peng. A family of Z-source matrix converters. *IEEE Trans. Ind. Electron.* **2012**, 59 (1), 35–46.
12. Y. Zhang, Z. Cheng, Q. Chen, Q. Li. An Enhanced Half-Quasi-Z-Source Inverter for Wind Energy Conversion System with D-PMSG. *Complexity* **2021**, 2021, 1–15.

13. E. Karaman, M. Farasat, A.M. Trzynadlowski. Indirect matrix converters as generator-grid interfaces for wind energy systems. *IEEE J. Emerg. Sel. Top. Power Electron.* **2014**, 2 (4), 776–783.
14. O. Ellabban, H. Abu-Rub, S. Bayhan. Z-Source Matrix Converter: An Overview. *IEEE Trans. Power Electron.* **2016**, 31 (11), 7436–7450.
15. A. Jain, S. Shankar, V. Vanitha. Power generation using Permanent Magnet Synchronous Generator (PMSG) based variable speed wind energy conversion system (WECS): An overview. *J. Green Eng.* **2018**, 7 (4), 477–504.
16. S. Bala Kumar, S. Kefale, M. Azath. Comparison of Z-source EZ-source and TZ-source inverter systems for wind energy conversion. *Int. J. Power Electron. Drive Syst.* **2018**, 9 (4), 1693–1701.
17. M.A. Ismeil, A. Bakeer, M. Orabi. Implementation Quasi Z-source inverter for PV applications based on finite control set-model predictive control. *Int. J. Renew. Energy Res.* **2019**, 9 (3), 1462–1471.
18. Y. Mastanamma, D. Subbarayudu. Permanent magnet synchronous generator for wind energy conversion systems (WECS): A review. *Int. J. Recent Technol. Eng.* **2019**, 7 (ICETESM18), 217–221.
19. D. Mande, J.P. Trovão, M.C. Ta. Comprehensive Review on Main Topologies of Impedance Source Inverter Used in Electric Vehicle Applications. *World Electr. Veh. J.* **2020**, 11 (2), 37.
20. Y. Liu, X. Chen, M.R. Islam. Converter-Based Advanced Diagnostic and Monitoring Technologies for Offshore Wind Turbines. *Emerg. Power Convert. Renew. Energy Electr. Veh.* **2021**, 225–280.
21. J. Zakis, D. Vinnikov, I. Roasto, L. Ribickis. Quasi-Z-source inverter based bi-directional DC/DC converter: Analysis of experimental results. *2011 7th Int. Conf. Compat. Power Electron. CPE 2011 - Conf. Proc.* **2011**, 394–399.